

How the GreasePaK DMI dosing unit Operates

GreasePaK DMI unit is **factory set to automatically deliver a medium dose of GreasePaK fluid into the kitchen drain each night**. Each 28 -30 days when the 5L fluid box is changed, a high 'boost' dose is automatically delivered.

The **secure electronic controls** allow the kitchen manager or installer to change the delivery time and volume to suit the individual kitchen requirements with **the simple push of a button**.



During its operational cycle, **a simple fluid level display** advises the kitchen operator how much fluid remains. A low-level fluid / empty warning display will appear when the MSGD fluid box requires replacing. When empty, the box is simply exchanged for a new refill and connected via a simple unique twist-action quick-connect valve, that **will not allow leakage or liquid loss** on change over.

The GreasePaK DMI is **key-lockable** for situations where restricted access is required.

Best Location:

For best location advice please contact Mechline or refer to www.mechline.com

GreasePaK can be used in conjunction with a grease trap [dosed prior to the trap] or as a stand-alone effective means of FOG removal and drain maintenance.



GreasePaK DMI Dimensions:

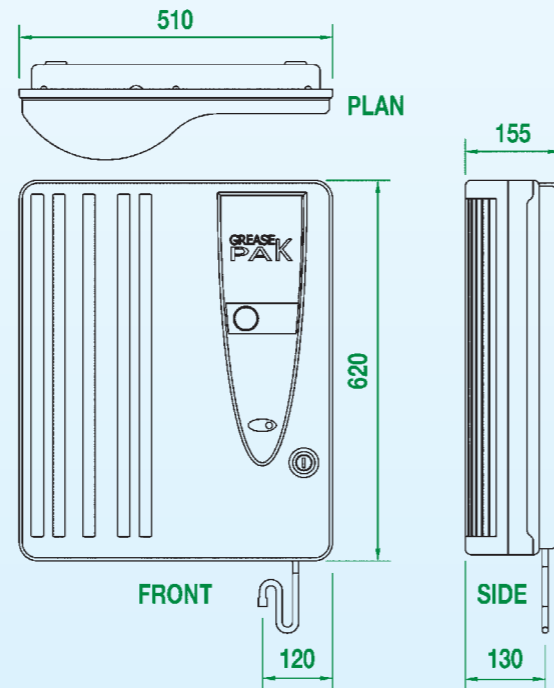

Technical: The GreasePaK DMI is **battery operated*** - there is no mains electrical requirement. Unique technology provides a battery life of up to 2 years before a simple battery change. A low battery warning light advises the operator when the battery requires changing, which is an easy operation.

*Mains-powered units are available upon request.

Unique control valve technology incorporated within the DMI unit removes the need for peristaltic pumps and reduces service and maintenance requirements.

No Water connection is required. The GreasePaK DMI unit simply requires connection directly into kitchen drains or into grease traps. Fixing kit provided.

With no requirement for water or mains electrical connections GreasePaK can be installed almost anywhere in the kitchen.



GreasePaK distributed by:



MECHLINE

Unit 15 Carters Lane Kiln Farm
Milton Keynes MK11 3ER
T: 01908 261511 F: 01908 261522
E: info@mechline.com W: www.mechline.com

Bright *ideas* for professional kitchens

Biological Drain Maintenance System



A **Unique**, automatic drain dosing system specifically designed to address the drainage problems found in commercial kitchens. GreasePaK's highly developed and powerful Bio-Enzymatic solution deals with **Fats, Oil and Grease [FOGs]** leaving staff free to run the kitchen.



- GreasePaK maintains free running drains, decreases odours and avoids blockages.
- Helps foodservice operators meet with legislative demands.
- Stylish easy-to-clean dosing module.
- No Water or Electrical connections.
- Easy to install, easy to use, easy to maintain. Simple.
- GreasePaK refills are very easy to store, handle and change.
- An effective, environmentally friendly commercial solution.

Bright *ideas* for professional kitchens **MECHLINE**

Kitchen Drains and Grease

Commercial kitchens naturally discharge high levels of fats, oils and greases into the drains. This can result in slow drains and blockages which release bad odours and create unacceptable health and hygiene hazards in the kitchen.

UK Building Regulations 2000, amended in April 2002, state that:

H1: Foul Water Drainage 2.21 Drainage serving kitchens in commercial hot food premises should be fitted with a grease separator complying with prEN 1825-1 and designed in accordance with prEN 1825-2 or other effective means of grease removal.

A commercial kitchen without an effective means of grease removal contravenes the regulations. **GreasePaK** is a very effective means of grease removal – that can work with grease traps or on its own.



Traditional Solution – Grease traps

Bulky grease traps are expensive to install, can take up valuable space and can be very difficult to clean around, creating further hazards.

Suitable for Commercial Kitchens?

Grease traps need emptying and managing, which rarely happens. Lack of maintenance leaves a foul water reservoir, which becomes odorous and attracts vermin and insects. Cleaning grease traps is a foul job, which can result in kitchen contamination. **If you worked in a kitchen, would you want to dredge out the grease trap?**

Applied Bio-Chemistry – Traditional dosing system solution

Bio-enzymatic treatment is a recognised means of degrading Fats, Oils and Grease (FOGs) deposited into kitchen drains.

Traditional dosing systems rely on **large bulky drums** of chemical positioned on the kitchen floor with a mechanical pump.

The large drums take up **valuable kitchen floor space**, are difficult to clean around and can weigh up to 25kg each, creating potential HACCP issues. Spillages can be **extremely difficult to clean up**.



GreasePaK DMI – Dosing unit

GreasePaK DMI is a **stylish, discreet and easy-to-clean, self-contained** wall-mounted dosing unit that takes up **no floor space** and is **very simple to install and operate**.

The GreasePaK DMI holds a **single, lightweight, ready-mixed** GreasePaK MSGD 5-litre box of grease degrader fluid.



GreasePaK MSGD 5 – Drain maintenance fluid

Mechline GreasePaK fluid is a highly effective product specially developed for its **ability to degrade Fats, Oils and Grease** [FOGs]. The GreasePaK MSGD is a Multi-Strain Grease Degradator with a formula of many different naturally occurring, non-pathogenic bacteria, containing in excess of **500 million 'bugs' per gramme**.

Highly Effective:

The bacteria in GreasePaK MSGD are fast-growing and release a battery of powerful enzymes that quickly and efficiently break down FOGs and other organic matter blocking drainage systems. The advanced formulation works in challenging situations

where standard industry products are less efficient. GreasePaK MSGD is **highly effective in conditions of low dissolved oxygen (such as closed drains)** and where pH levels fluctuate.

Tried and Tested:

GreasePaK MSGD fluid is the culmination of **15 years research** into the breakdown and degradation of FOGs and is considered **the most powerful product of its type** used in commercial kitchens. Other products used are commonly single strain grease degraders, with far lower bacteria counts.



Environment and Safety:

GreasePaK MSGD is an environmentally friendly **Class 1** biodegradable product that degrades FOGs into smaller, simpler molecules that **cannot reform or solidify**. These degraded products are then further digested by the bacterial population or are quickly washed away.

With daily dosing, the bacteria in GreasePaK will colonise the drain pipework to form a 'Biofilm' - an active bio-enzymatic coating that **will regenerate itself and produce a continuous supply of highly active enzymes for FOG degradation**.

GreasePaK MSGD requires **no special operational, handling or storage procedures**.

